

"Every man serves a useful purpose: A miser, for example, makes a wonderful ancestor."

- Laurence J. Peter



Topics

Entertainment, Cable TV, and Last-Mile Fiber Systems

Setting up a DHCP Server

Setting up a DNS Server

Chapter 14 Entertainment, Cable TV, and Last-Mile Fiber Systems

Wires, Wires, Wires...

How Many Wires are coming into the house?

Telephone
Cable
Power

Can any one of them provide all the services - or at least knock out another?

Cable Multiple Operators (MSOS)

Cable Company	Number of Subscribers
Comcast Cable Communications	21.5 million
Time Warner Cable (part of AOL Time Warner)	10.9 million
Charter Communications	6.2 million
Cox Communications	6.4 million
Adelphia Communications	5.4 million
Cablevision Systems Corporation	2.9 million
Bright House Networks	2.2 million

History

Analog Cables - repeaters every .5 mile

Fiber Optics
Higher Quality
More Channels

Fiber Nodes
Service 250-1000 homes

Hybrid Fiber Cable System

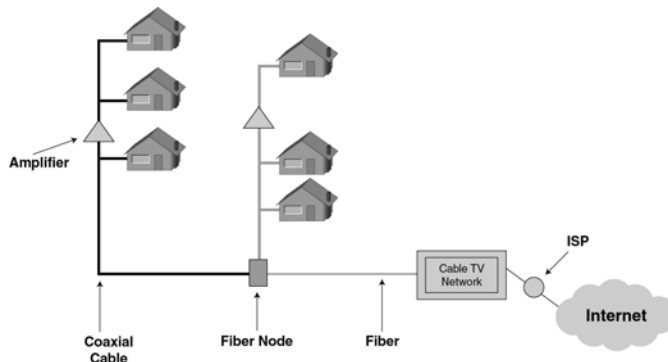

Reverse Channels

Cable TV is one way - down to you

Broadband requires two-way service

Reverse channels created using different frequencies

Cable Modem Standards

Standard	Capabilities
DOCSIS 1.0	Two-way service for Internet access Upstream speed of 5Mbps (megabits per second) Uniform specifications so that cable modems can be purchased from retail outlets and be compatible with cable operators' infrastructure
DOCSIS 1.1	Increases the upstream speed to 10Mbps (megabits per second) Improves security and privacy Quality of service (QoS) to enable operators to provide differentiated quality for Voice over IP and interactive services such as real-time multiplayer games Tier-based services such as higher speeds to heavy users who use more bandwidth or purchase additional data services
DOCSIS 2.0	Increases upstream speed to 30 megabits per second Symmetric services such as those for business customers Peer-to-peer such as VPN with site-to-site connectivity (see Chapter 5 for VPN service)

Cable Modem Network

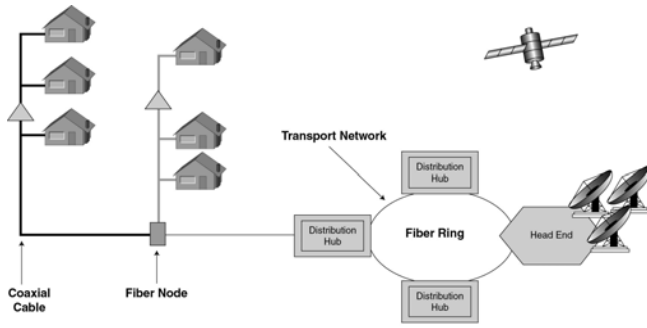

Expanded Services

- Pay Per View
- Video and TV on Demand
- Voice over IP
- Digital TV
- Movie to TV Windows

The Triple Play

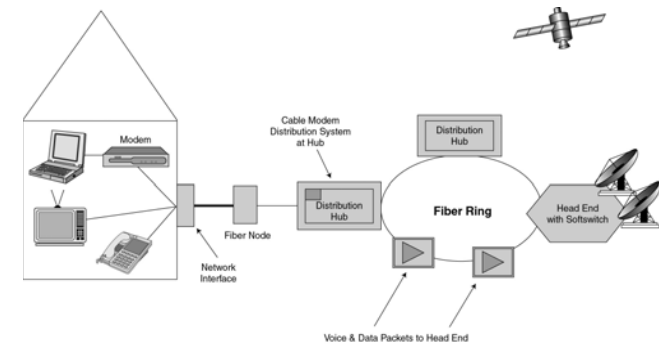

Possible expand to Wireless as well...

Set Top Boxes

- Decoding
- Security
- Billing
- Program Guides
- Personal Video Recorders
- Digital Photos
- Music
- Games

Direct Broadcast Satellite TV

- Satellite Dish
- Decoder Box
- Typically One-way systems
- Uplink via phone or network

Over the Air Broadcast



National Broadcasters (ABC, CBS...)
Local Affiliates, Regional Differences

Digital TV

- Do Not Record Flag
- Equipment Upgrades
 - Broadcast Receivers
 - Video
- Uses less bandwidth

Broadcast HDTV

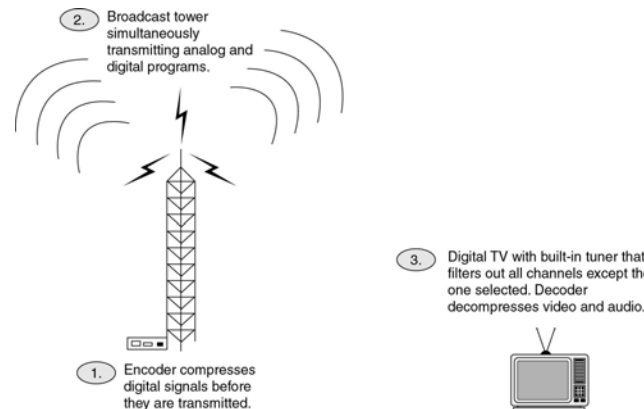

Digital Cable TV

- Lower Resolution than HDTV broadcast
- Reasons
 - Bandwidth Limitations
 - Costs involved in upgrading Set top boxes

Legally Downloading Movies

The MPAA and movie studios still don't get it...

- Lower Quality
- Higher Prices
- Fewer Features
- Slow Download
- Limited Playback (PC or TV)
- Digital Right Management

Satellite Radio Fees vs. Advertisements

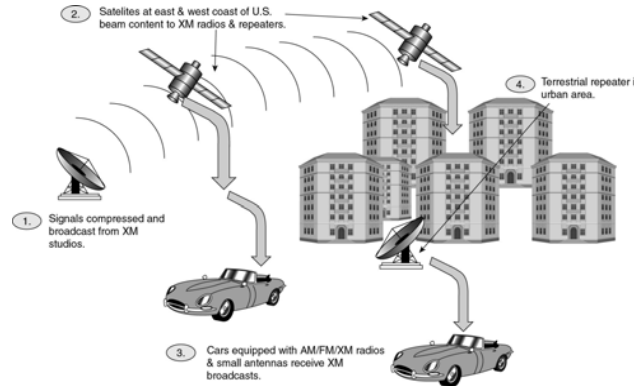

FTTx

Fiber to the _____

- Premises
- Curb
- Neighborhood
- Basement

Passive Optical Networks

PONs

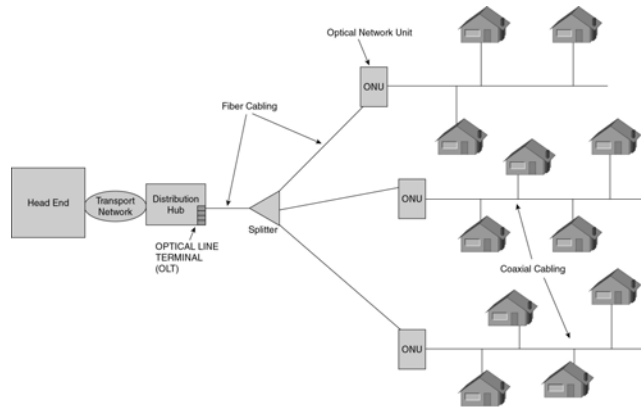

Fiber to the Home

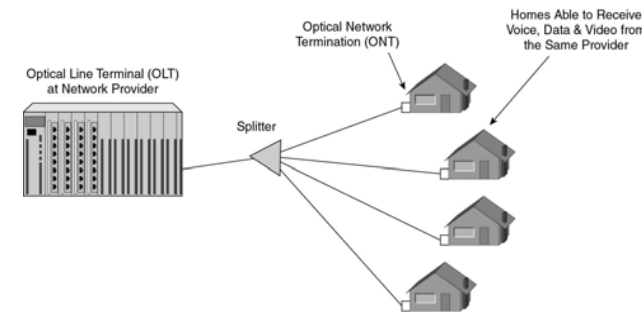

PONs Bandwidth

Table 6.3 Passive Optical Network Standards

	APON ATM PON	BPON Broadband PON	EPON Ethernet PON	GPON Gigabit Ethernet PON
Speed	622Mbps* (OC 12) downstream 155Mbps* (OC 3) upstream	622Mbps* upstream and downstream	1Gbps** upstream and downstream	2.5Gbps** downstream 1.25Gbps* upstream
Comments	Earliest PON standard	A faster version of APON	Newer than APON Not as flexible for handling IP as GPON	Newest standard Most efficient for IP traffic

Choices

- The impact of Netflix
- Do people want to watch movies or TV reruns on their PCs?
- Or Cell Phones?
- On their i-Pods
- Home networks
- Technological factors

MSOS vs Telcos

- Cable operators' competitive advantages
- Telco strengths
- Regulatory issues
- Local franchises
- National legislation

Win2k

DHCP

DHCP

Dynamic Host Configuration Protocol

Automatically assign to node

IP Address
Subnet Mask
Gateway
etc....

DHCP

Dynamic Host Configuration Protocol

Easier IP addressing
Server has a block of addresses
Server has a Subnet masks
Server leases address to client

DHCP

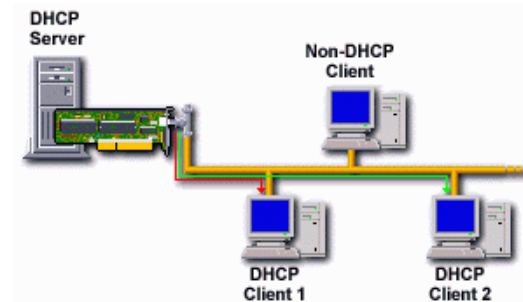

How DHCP Works

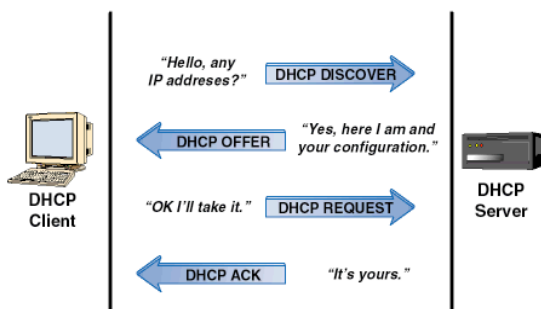

Leases

How long does a client keep the IP address?

Leases set the time frame

Allows higher turn over of IP

IP address renewed at 50%
Try again at 87.5%
No response, release

DHCP States

DHCP Client States

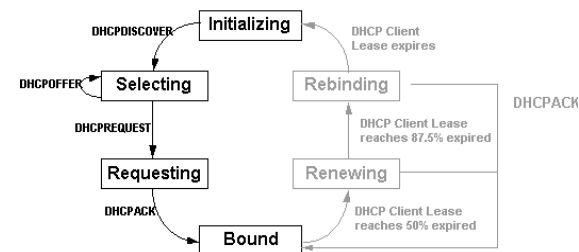

Demo

Setting up DHCP

Windows 2000 Advanced Server

Add services for DHCP

Fixed IP Address for server

Clients

Turn off Wireless
Wired - use Auto configuration
Firewalls are OK

Windows 2000 Advanced Server

Administrative Tools
DHCP

New Scope Wizard

On the client
Set for DHCP
ipconfig /release
ipconfig /renew

What addresses are you getting?

Win2k

DNS

DNS

Domain Name System (DNS) enables you to use hierarchical, friendly names to locate computers and other resources.

DNS is the de facto naming system for Internet Protocol (IP)—based networks and the naming service that is used to locate computers on the Internet.

Name Resolution

Internet use IP address
211.173.195.229

We prefer Names
www.cnn.com

Name Resolution Devices

DNS - Domain Name Server
WINS - Window Internet Name Service

The Big Picture

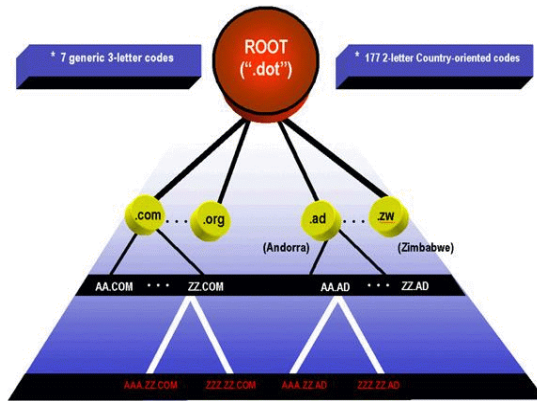

DNS

Hierarchical name space

TLD - Top level domain
.edu .com .gov...

FQDN

Fully Qualified Domain Name
Nt123.usfk.korea.army.mil

Domain Namespace

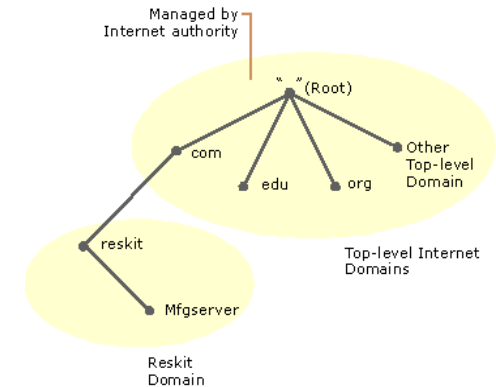

Three Types of TLDs

Organizational domains

Geographical domains

Reverse domains

Also:

IP6.INT, used for IP version 6 reverse lookups.

Organizational domains

3-character code that indicates the primary function or activity of the organizations contained within the DNS domain.

Generally only for organizations within the US

TLD

.com
.edu
.gov
.int
.mil
.net
.org

Geographical domains

These are named by using the 2-character country/region codes established by ISO 3166

.ad Andorra
 .ca Canada
 .uk United Kingdom
 .tv Tuva
 .zw Zimbabwe

Reverse domains

This is a special domain, named in-addr.arpa, that is used for IP address-to-name mappings (referred to as reverse lookup).

1.10.16.172.in-addr.arpa

Basic DNS Concepts

DNS servers

DNS resolvers

Resource records

Zones

Zone Files

DNS servers

Contains DNS database information about the DNS domain tree structure

DNS servers also attempt to resolve client queries.

DNS resolvers

Programs that use DNS queries to query for information from servers

Resolvers can communicate with either remote DNS servers or the DNS server program running on the local computer

Resource records

Sets of information in the DNS database that can be used to process client queries

Each DNS server contains the resource records it needs to answer queries for the portion of the DNS namespace for which it is authoritative

Zones

Contiguous portions of the DNS namespace for which the server is authoritative

A server can be authoritative for one or more zones

Zone files - text files that contain resource records for the zones for which the server is authoritative

DNS Servers

Primary

Secondary

Obtains DNS info from Primary
 Zone Transfers
 Fault Tolerance
 Reduction of Traffic
 Reduced load on Primary

DNS Servers

Caching Only Server

simply perform queries, cache the answers, and return the results. They are not authoritative for any DNS domains and do not host any zones. They only store data that they have cached while resolving queries.

Load Sharing DNS Servers

To prevent overload

```
www.reskit.com. IN A 172.16.64.11
www.reskit.com. IN A 172.16.64.22
www.reskit.com. IN A 172.16.64.33
```

Name server set up for round-robin

Putting it all together

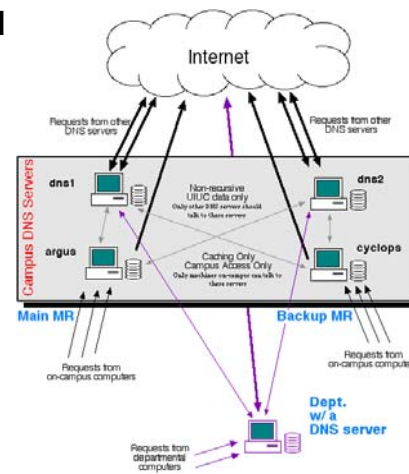

Recursive and Iterative Queries

Recursive
Keep trying

Iterative
Best Answer

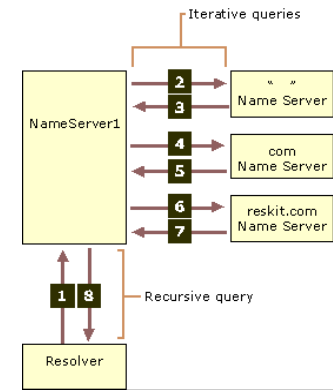

Resource Record Types

Most Common

- SOA
- NS
- A
- PTR
- CNAME
- MX

SOA Resource Records

Every zone contains a Start of Authority (SOA) resource record

Includes:

- Owner, TTL, Class, and Type
- Authoritative server
- Responsible person
- Serial number
- Refresh, Retry, Expire
- Minimum TTL

Example SOA

```
noam.reskit.com. IN SOA (
  noamdc1.noam.reskit.com. ; authoritative server for
                           zone
  administrator.noam.reskit.com. ; admin e-mail
                               ; (responsible person)

  5099 ; serial number
  3600 ; refresh (1 hour)
  600 ; retry (10 mins)
  86400 ; expire (1 day)
  60 ) ; minimum TTL (1 min)
```

NS Resource Records

The name server (NS) resource record indicates the servers authoritative for the zone.

```
noam.reskit.com. IN NS
  noamdc1.noam.reskit.com.
```

A Resource Records

The address (A) resource record maps an FQDN to an IP address, so the resolvers can request the corresponding IP address for an FQDN.

```
noamdc1 IN A 172.16.48.1
```

PTR Records

The pointer (PTR) resource record, in contrast to the A resource record, maps an IP address to an FQDN.

```
1.48.16.172.in-addr.arpa. IN PTR
  noamdc1.noam.reskit.com.
```

CNAME Resource Records

The canonical name (CNAME) resource record creates an alias (synonymous name) for the specified FQDN

```
ftp.noam.reskit.com. IN CNAME  
ftp1.noam.reskit.com.
```

MX Resource Records

The mail exchange (MX) resource record specifies a mail exchange server for a DNS domain name

```
*.noam.reskit.com. IN MX 0  
mailserver1.noam.reskit.com.  
*.noam.reskit.com. IN MX 10  
mailserver2.noam.reskit.com.
```

Demo

Setting up DNS

Windows 2000 Advanced Server

Administrative Tools
DNS

New Zone Wizard

Add DNS to DHCP Server
Renew your DHCP

Try to ping...

End of Lesson